

Using a Function/Arbitrary Waveform Generator to Generate Pulses

Application Note 1437

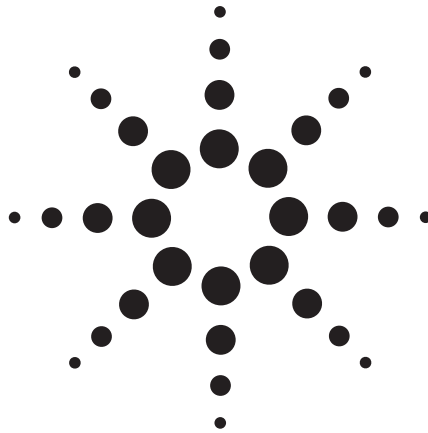

Engineers typically use pulse generators to create pulses for characterizing digital devices. A pulse generator is well suited for applications that require fast transition times, high accuracy or frequencies higher than 50 MHz. A dedicated pulse generator may offer multiple channels, pattern generation, double pulses, RZ (return-to-zero) pulses, and the ability to add jitter to the pulse train. When you are testing complex logic, these features give you the capabilities you need to get your job done.

However, if your application does not require the performance of a dedicated pulse generator, you can use a relatively inexpensive general-purpose function generator to create pulses. These applications include creating trigger signals, clock signals, and controlling logic.

Some function generators now offer robust pulse functionality. Look for a pulse button on the front panel that lets you define primary pulse characteristics, or check the instrument's

specifications. The instrument's data sheet should specify the parameters for a pulse: 1) shortest and longest period, 2) shortest and longest pulse width expressed in either seconds or duty cycle percentage, 3) shortest and longest variable edge time, 4) percentage overshoot, and 5) jitter, expressed as a percentage or ppm.

This application note explains several techniques you can use to create pulses with a function generator. We will use an Agilent 33250A, a modern function/arbitrary waveform generator that has built-in 50 MHz pulse capability. Pulse parameter specifications for the 33250A are listed in Table 1.

Period	20.00 ns to 2000.0 s
Pulse width	8.0 ns to 1999.9 s
Variable edge time	5.00 ns to 1.00 ms
Overshoot	<5%
Jitter (rms)	100 ppm + 50 ps

Table 1: 33250A pulse specifications



Methods for creating pulses with a function generator

A function generator offers several methods for generating pulses.

- Vary the duty cycle of a square wave – The most common way to create a pulse is to vary the duty cycle of a square wave. A square wave, by definition, has a 50 percent duty cycle, meaning the square wave is high for half the period and low for the other half. A function generator typically can vary the duty cycle from 20 percent up to 80 percent. Using burst mode, you can achieve an even lower duty cycle. This easy method of creating pulses and pulse trains is described in Application Note 1407. Most function generators let you create pulses by varying the duty cycle of a square wave or by using burst mode.
- Use the built-in pulse capability of newer function generators – This method is easy and provides lots of flexibility, but not all function generators have this built-in capability. This method is described below.
- Use arbitrary waveforms – You can create a wide variety of custom pulses and patterns using the arbitrary waveform capabilities of a function/arbitrary waveform generator to define the desired shape and parameters. While this is not the easiest approach, it does offer lots of flexibility (limited only by memory depth). Most function generators have the required arbitrary waveform capability. This method is also described below.

Using a function generator's built-in pulse generation capability

Having pulse generation capability built into a function generator makes it easy to create pulses;

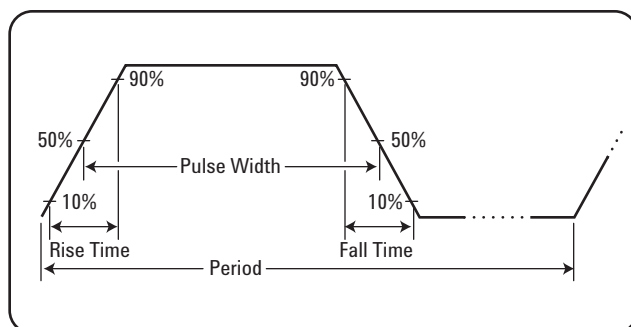

Figure 1: Pulse waveform parameters

you simply specify the main parameters of a pulse: period, pulse width and edge time (rise/fall time).

On the 33250A function generator, the pulse is specified in almost the same way as it is in a dedicated pulse generator. A dedicated pulse generator describes pulse width as the time from the leading edge to the beginning of the falling edge. Because it uses this definition, you can set the rise and fall times independently without effecting the time between the leading edge and the beginning of the falling edge.

The 33250A function generator also lets you vary the edge time without affecting the pulse width by using the same edge time for both rise and fall times. The 33250A sets the pulse width between the 50 percent level on the rising and falling edge. Because the edge times are the same, the pulse width value will be the same whether it is measured from the beginning of the edges, or if it is measured between the midpoints of the edges. Oscilloscopes also measure pulse width from the 50 percent level of the edges. If you use a pulse generator to create a pulse with different rise and fall times, the oscilloscope measurement of pulse width will not match the setting on the pulse generator.

The ability of a function generator to accurately produce a specified pulse will depend on the instrument. Function-generator hardware is designed to reproduce a variety of waveforms – everything from sine waves to arbitrary waveforms. A pulse generator, on the other hand, is designed specifically for pulse waveforms. Modern function generators typically generate waveforms through direct digital synthesis (DDS). A major advantage of DDS over other waveform-generation technologies is its ability to seamlessly change the frequency of a waveform by using more or fewer points, effectively sampling the stored data, in order to output the waveform. While DDS works well for waveforms that have smooth transitions, it does not always work well for pulses. DDS technology can sample the data in memory differently each time the waveform is output, causing jitter. To overcome these issues, the 33250A uses dedicated hardware to more accurately generate pulses.

For pulse waveform generation, the 33250A counts clock cycles to derive both the period and the pulse width. To achieve fine period resolution, the clock frequency is varied from 100 MHz to 200 MHz by a phase-locked loop (see Figure 2), and an analog delay (0 to 10ns) is applied to the trailing edge. A circuit that varies the charging currents in a capacitor

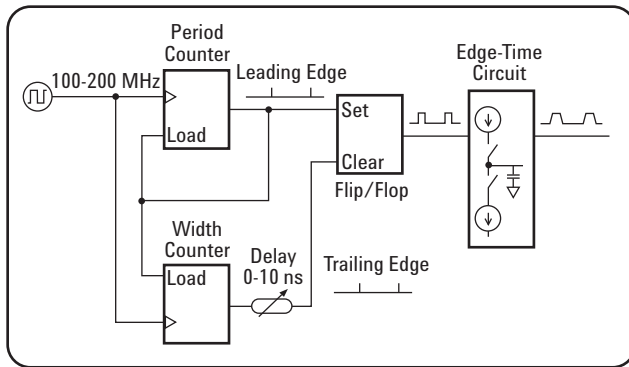

Figure 2: 33250A pulse-waveform-generation circuitry

controls the rising and falling edge times. The 33250A hardware uses these internal circuits, allowing you to independently control period, pulse width and edge times.

Using arbitrary waveforms

You also can create pulses through the use of arbitrary waveforms. At low frequencies, the DDS technology will not present a problem. However, at higher frequencies, transition times and cycle-to-cycle jitter equivalent to one period of the sample clock become more of an issue to overall performance. Creating a pulse or train of pulses in arbitrary waveform memory allows endless possibilities – limited only by memory depth – for the shape of the pulse. For best results, you will generally want to use all of the available points to describe the pulse. Using more points will provide better time resolution. Using a PC and an application for generating arbitrary waveforms will help simplify the task. Agilent offers a free IntuiLink Waveform Editor application specifically for creating and downloading arbitrary waveforms. In addition, a free software add-in is available for creating pulses with variable rise/fall times. Rise/fall times shapes can be linear, exponential, half-cosine, or Gaussian. The software add-in is intended for use with slow (greater than 100 nsec) edge times.

Once you have configured the function generator to generate the desired pulse or pulse train, you can use triggering to further define the output. You can create a single pulse or a burst of pulses using triggering. Most function generators can accept an external trigger as input and most also provide an external trigger signal. You can set a delay programmatically or from the front panel to offset the pulse from the external trigger, if desired.

Summary

Function generators offer quite a bit of flexibility for creating pulses from simple modified square waves to arbitrary waveforms. Some function generators may even have special hardware added to generate very accurate pulses. For high-speed pulse applications, a dedicated pulse generator will be necessary and will offer additional features for creating pulses.

Glossary

Direct digital synthesis (DDS) – a method of generating a waveform by taking points of a sampled waveform stored in memory and applying them to the digital port of a digital-to-analog converter. The DAC is clocked at a constant rate, and frequency adjustments are made by repeating a single memory location for multiple clock cycles to obtain low frequencies, while high frequencies are obtained by sampling the stored points.

Rise time – the time it takes to transition from low to high state; often measured at the 10 percent and 90 percent levels.

Fall time – the time it takes to transition from high to low state; often measured at the 10 percent and 90 percent levels

Edge time – the rise and/or fall time; some instruments may use edge time as a means to set both the rise and fall time to equal values

Pulse width – the amount of time a pulse remains at a specific (normally “true”) logic state. Can either be measured from 1) the time between the leading edge at 50 percent amplitude to the trailing edge at 50 percent amplitude 2) the time from the beginning of the leading edge to the beginning of the trailing edge

Duty cycle – the ratio of the pulse width to the pulse period measured in percent

Period – the repetition rate of a waveform measured in seconds; for the purposes of this article, the time between pulses; also, the inverse of frequency

Double pulse – used in communication; two short pulses are output during a single period

Return-to-zero (RZ) pulse – a pulse that has a positive leading edge and a trailing edge that occurs within in the pulse period

Non-return-to-zero (NRZ) – a pulse that does not transition during the pulse period but rather remains at either the high or the low state

TTL (transistor transistor logic) – a standard definition for digital logic based upon 0 Vdc and a 5 Vdc supply voltage

BNC (Bayonet Neill Concelman) – a type of bayonet (twist-lock) coaxial connector commonly used in connections involving small coaxial cables

Arbitrary waveform – a waveform that has been digitally defined and placed in memory. The analog waveform is produced by applying the waveform memory content to a digital-to-analog converter (DAC) and filtering the output.

Phase-lock loop – an electronic circuit with a voltage-controlled oscillator, which is constantly adjusted to match in phase and lock to the frequency of an input signal.

Linear edge – a transition in logic state that occurs at a constant rate. Used for simulating an ideal waveform.

Exponential decay edge – a pulse transition that maximizes the amount of change at the beginning of the transition. Used to simulate capacitive loading.

Half-cosine edge – a pulse transition that minimizes the rate of change at both ends of the transition. Used in communications to minimize bandwidth.

Gaussian edge – a curve that depicts the frequency of distribution for many natural phenomena. Used to simulate the cumulative effects of random events.

Related Agilent Literature

Data sheet – 33120A 15 MHz Function/arbitrary Waveform Generator, pub no. 5968-0125EN

Data sheet – 33250A 80 MHz Function/arbitrary Waveform Generator, pub no. 5968-8807EN

Application note – How to Generate Low Duty-Cycle Pulses with a Function Generator, pub no. 5988-7507EN



Agilent Email Updates

www.agilent.com/find/emailupdates

Get the latest information on the products and applications you select.

Agilent T&M Software and Connectivity

Agilent's Test and Measurement software and connectivity products, solutions and developer network allows you to take time out of connecting your instruments to your computer with tools based on PC standards, so you can focus on your tasks, not on your connections.

Visit www.agilent.com/find/connectivity for more information.

By internet, phone, or fax, get assistance with all your test & measurement needs

Online assistance: www.agilent.com/find/assist

Phone or Fax

United States:

(tel) 800 452 4844

Canada:

(tel) 877 894 4414

(fax) 905 282 6495

China:

(tel) 800 810 0189

(fax) 800 820 2816

Europe:

(tel) (31 20) 547 2323

(fax) (31 20) 547 2390

Japan:

(tel) (81) 426 56 7832

(fax) (81) 426 56 7840

Korea:

(tel) (82 2) 2004 5004

(fax) (82 2) 2004 5115

Latin America:

(tel) (305) 269 7500

(fax) (305) 269 7599

Taiwan:

(tel) 0800 047 866

(fax) 0800 286 331

Other Asia Pacific Countries:

(tel) (65) 6375 8100

(fax) (65) 6836 0252

(e-mail) tm_asia@agilent.com

Product specifications and descriptions in this document subject to change without notice.

© Agilent Technologies, Inc. 2002

Printed in the USA December 13, 2002

5988-8472EN

