

# 8 Hints for Making Better Measurements Using Analog RF Signal Generators

Application Note 1306-1

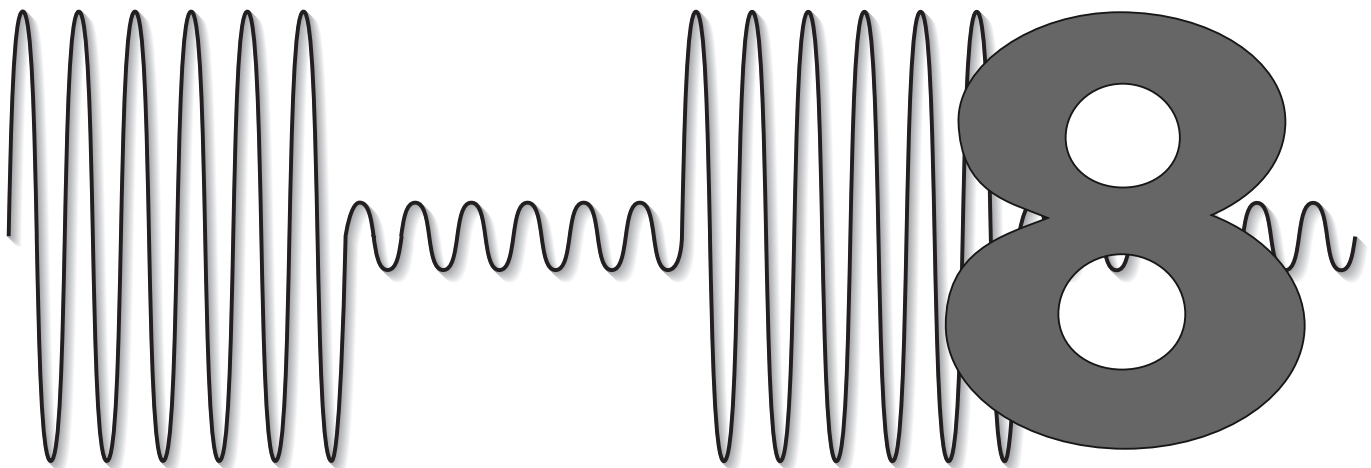
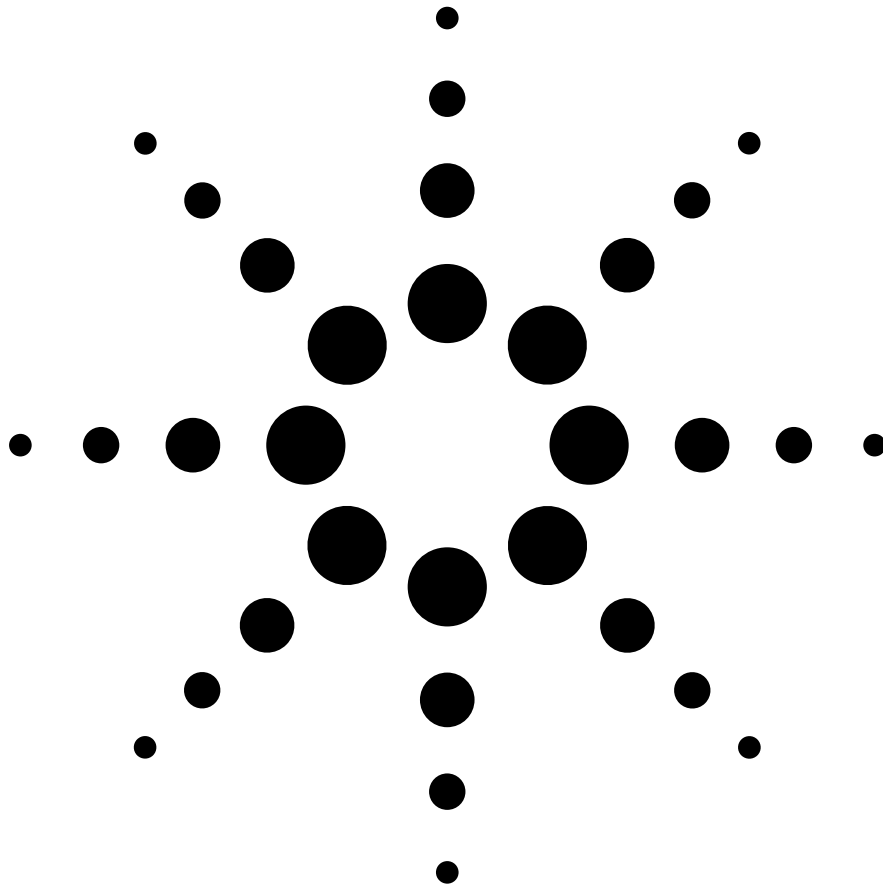

Agilent Technologies

Signal sources provide precise, highly stable test signals for a variety of component and system test applications. Signal generators add precision modulation capabilities, and are used to simulate system signals for receiver performance testing.

This guide helps you improve the accuracy of your measurements that involve using RF analog signal sources. You may increase the accuracy of your data by using more than one of the hints in your test setup.

**HINT 1.  
Improve Source's Effective  
Harmonic Distortion**

Use a low pass filter at the output of your source to decrease its harmonic distortion.

**HINT 2.  
Increase Power Level Accuracy**

Use a power meter to increase the accuracy of the signal level at your device under test (DUT).

**HINT 3.  
Improve Frequency Accuracy**

Select the appropriate frequency reference to improve absolute or relative frequency accuracy.

**HINT 4.  
Improve Source Match**

Use a fixed attenuator to reduce the mismatch error.

**HINT 5.  
Combine Source Outputs for TOI  
Measurements**

Use a proper setup to isolate sources, improve match.

**HINT 6.  
Improve FM Deviation Accuracy**

Use the Bessel Null method to set your signal generator's frequency deviation.

**HINT 7.  
Extend the Amplitude Range**

Use an amplifier or an attenuator to increase or decrease respectively, the amplitude range of your signal source.

**HINT 8.  
Select the Optimum Phase Noise  
Profile**

Choose the appropriate phase noise profile to optimize in-channel or out-of-channel measurements.

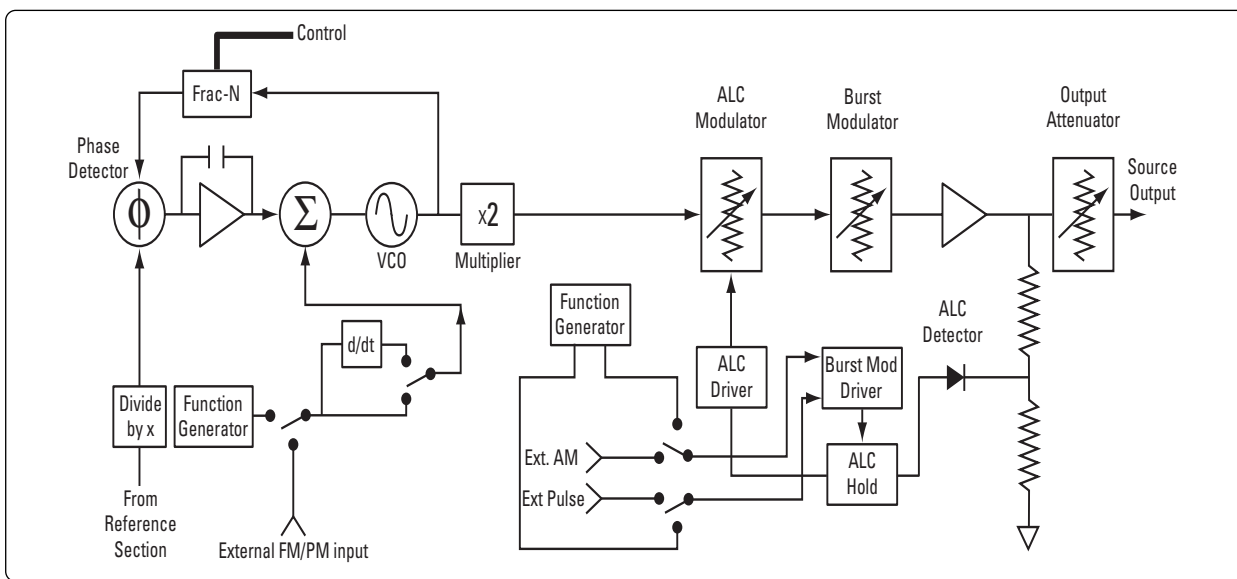

**Typical Signal Generator Block Diagram**

**HINT 1.**  
**Improve source's effective harmonic distortion**

Accurate harmonic distortion measurements require a spectrally pure signal source and a spectrum analyzer. The harmonic distortion of the signal source and the dynamic range of the spectrum analyzer limit the quality of the measurement. However, the signal source is often the limiting factor, with harmonic distortion performance on the order of 30 dB below the fundamental. Figure 1 shows a typical harmonic distortion measurement.

The harmonic distortion of a signal is often specified by stating the amplitude of the largest harmonic in dB relative to the fundamental.

Use a low pass filter to improve the source's effective harmonic distortion, as shown in Figure 2. Choose the cutoff frequency of the low pass filter such that the fundamental frequency is passed largely intact, while the harmonics are attenuated significantly. You can verify the performance of the source/filter combination directly with the spectrum analyzer.

If the loss through the filter at the fundamental frequency is significant, the loss should be accounted for when setting the source output level. Use the spectrum analyzer to check the fundamental level at the output of the filter, or for better level accuracy see Hint 2.

**Note:** You can calculate the percent distortion for a particular harmonic, mth harmonic as,

$$\%d_m = 100 \times 10^{\left(\frac{\Delta dB}{20}\right)}$$

Or you can calculate total harmonic distortion: calculate the distortion for each harmonic as above and find the root sum of the squares,

$$\%THD = \sqrt{\sum (\%d_m)^2}$$

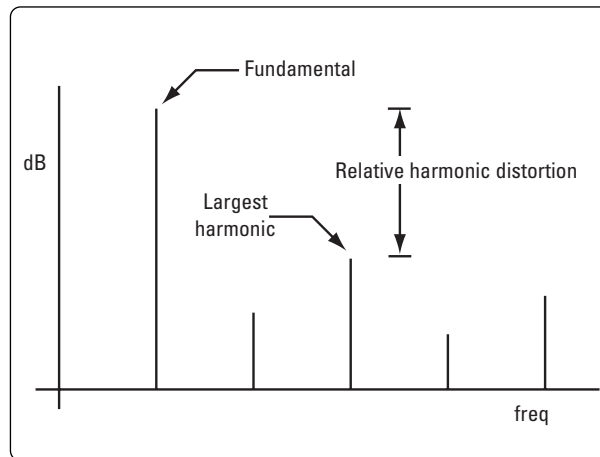

Figure 1.

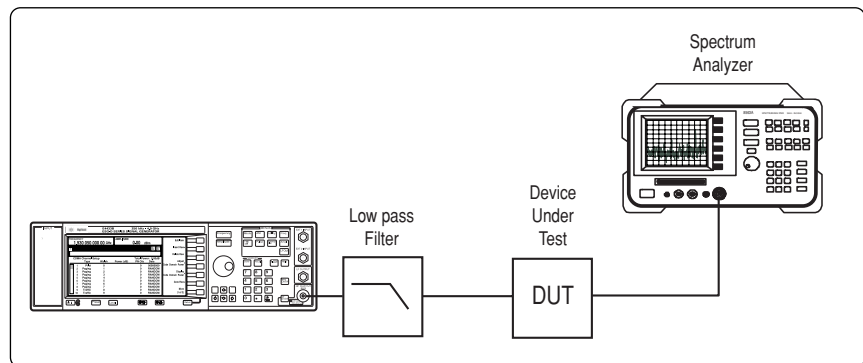

Figure 2. The harmonic distortion of a signal source improved by installing a low pass filter at the source's output.

## HINT 2. Increase power level accuracy

In your test setup, you are likely to use passive devices such as cables, filters or switches between your source and the DUT. The accuracy of the signal level at the DUT is effected by the use of these components. In some applications, for example receiver sensitivity measurements, the accuracy of the input signal level is critical. To have the desired power applied to the DUT, perform the following test prior to making your measurements. The setup consists of your signal generator, power meter with a power sensor and the cables or switches that are necessary in the measurement as shown in Figure 3.

Calibrate the power meter to the power sensor for an accurate power measurement. It is assumed that you are familiar with the calibration and zeroing of the power meter in use.

**Note:** the accuracy of the power meter measurement depends on the calibration factors of the sensor; be sure to enter the calibration factors into the power meter prior to calibration.

Once you have completed the calibration of your power meter, set the power meter's measuring frequency to the signal frequency. Connect the sensor in place of your DUT as indicated in Figure 3 and measure the power level. If there is a difference between the power meter's reading and the indicated level on the source, use your source's amplitude offset feature to make the necessary adjustments. Match the displayed power level of your source to the power meter's reading. Once you adjust the amplitude at a particular frequency, then the source will automatically display the correct value for different amplitudes at that same frequency. Since the accuracy of the power meter is very high (uncertainty in the tenths of a dB range), you can have confidence that the power level is accurate.

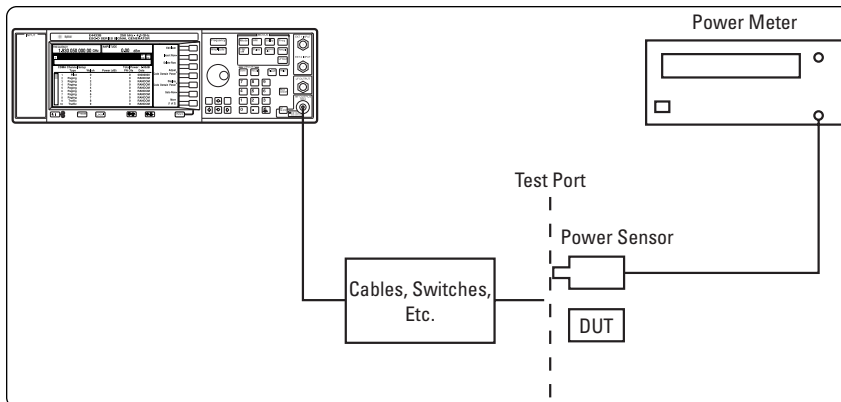

Figure 3. Setup for improving level accuracy of the signal.

### HINT 3. Improve frequency accuracy

For certain measurements, the absolute frequency of the stimulus signal is most important, but other measurements require accurate relative frequency spacing between multiple signals. For instance, to create multi-tone inputs with known frequencies more than one signal generator is often used. The frequency accuracy of each source relies on its internal frequency standard. It is very possible for these standards to be slightly off in frequency, thereby causing relative frequency errors in the measurement.

For example, assume you are trying to set a 1 kHz separation between two signals centered at 200MHz, and your sources have  $\pm 1 \times 10^{-6}$ /year aging rate. Your sources frequency error in this case is  $200 \text{ MHz} \times 1 \times 10^{-6} = \pm 200 \text{ Hz}$ . The separation could be anywhere from 600 Hz to 1400 Hz, (see Figure 4). To increase the accuracy, connect the time bases of the two sources together. Take the reference signal output of one source, usually located on the back panel of the box, and connect it to the reference signal input of the other source. Now the uncertainty of the separation is  $1 \text{ KHz} \times 10^{-6}$  or 0.001 Hz.

When the absolute frequency of the signal is important, increase the frequency accuracy of your source by finding the most accurate external-frequency reference available. Choose the instrument in your setup with the most accurate time base and connect all the other equipment to this reference.

Some instrument manufacturers offer high-stability ovenized reference oscillators as an option. These frequency and time standards are extremely accurate, but can be expensive.

You can always improve frequency accuracy by using a house standard (a high-accuracy frequency reference distributed throughout your facility). Connect your signal generators and all your other equipment to this reference. A distribution amplifier may be needed to maintain proper levels and impedance matching.

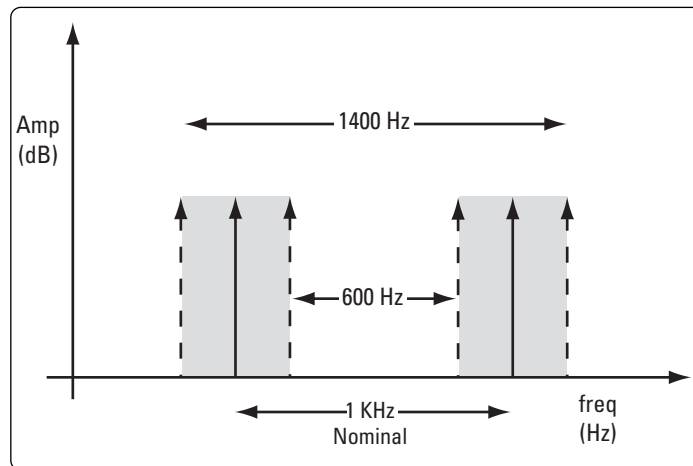

Figure 4. Shaded area illustrates the relative frequency error range of the example.

## HINT 4. Improve source match

Source match is important because many test devices present bad matches. Mismatch between the source and the load impedance changes the effective signal input level to the device under test. Complicating the picture, the test device is seldom connected directly to the source. There are cables and often other components, such as adapters and filters between the source and the load. If you are using adapters to accommodate the connector type of the test device, filters to eliminate source harmonics, and so forth, be aware that these components degrade the source match as seen by the test device. This mismatch may be reduced in several ways. The simplest way is to insert a fixed attenuator with good match at the input of the test device. This improves the effective source match by twice the value of the attenuator in dB.

When a load is not well matched, there is a reflection from the load, which travels back toward the source. Instead of being completely absorbed at the source, some of it is re-reflected back toward the load. This re-reflected wave adds constructively or destructively at the load, depending on the phase of the signal. From a measurement point of view, concentrate on the maximum and minimum power transfer, which represents the maximum and minimum error that can be incurred due to impedance matching problems.

The following example will help illustrate the difference inserting the attenuator will make in the measurement.

**Example**

Given: Source SWR = 1.9  
Device Under Test with SWR = 1.5

Find: Mismatch error

- Before inserting an attenuator

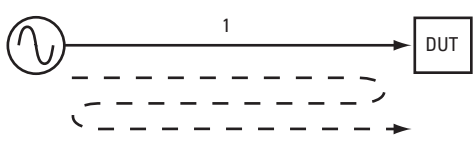

$$\rho_s = \frac{SWR-1}{SWR+1} = \frac{1.9-1}{1.9+1} = \frac{0.9}{2.9} = 0.31$$

$$\rho_D = \frac{0.5}{2.5} = 0.2$$

mismatch error =  $20 \log [1 + \rho_s \rho_D]$   
 $= 20 \log [1 + (0.31)(0.2)]$   
 $\approx 0.52 \text{ dB}$

max mismatch error  $\approx \pm 0.52 \text{ dB}$

- After inserting a 10 dB attenuator with  $r = 0.32$

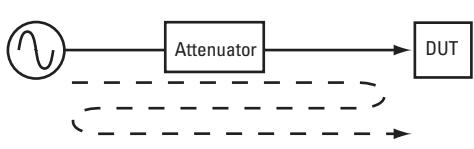

mismatch error =  $20 \log [1 + \rho_s \rho_D (\text{atten})^2]$   
 $= 20 \log [1 + (0.31)(0.2)(0.32)^2] \approx 0.055 \text{ dB}$

max mismatch error  $\approx \pm 0.055 \text{ dB}$

## HINT 5. Combine source outputs for TOI measurements

When combining two sources to make a third-order-intercept (TOI) measurement, it is important that your sources are terminated properly and well isolated from each other. If they are not isolated, the sources can intermodulate with one another, producing intermodulation products at the input of the device under test (Figure 5). This condition can mask the device's true intermodulation performance.

Each source wants to see a good 50-ohm termination. When using resistive combiners, be sure to use the three-resistor type, and not the two-resistor type. See figure 6. Two-resistor combiners/splitters are used for leveling applications where one side of the splitter connects to a power meter for accurate level control. For TOI applications, two-resistor combiners don't provide a 50-ohm match on all ports. In addition to providing proper termination at all three ports, three-resistor splitters provide 6 dB of isolation between the two sources.

The best way to combine two sources is to use a directional splitter or directional coupler. They provide good port matches and extra isolation.

You can improve isolation between the sources, regardless of what type of combiner is used, by adding attenuators at the output of each source (before the signals are combined). Increase the source power to compensate for the extra attenuation. Adding 10 dB attenuators to the output of each source increases the isolation by 20 dB. Another way to increase isolation is to place amplifiers after each source. The reverse isolation of the amplifiers typically provides plenty of isolation between the two sources.

For some sources, turning off the output automatic-level-control (ALC) will decrease intermodulation products. This prevents conflict in power-level control between the two sources. This is less of a problem for wide frequency offsets (100 kHz and higher, typically) since most ALC bandwidths are fairly low when AM is turned off.

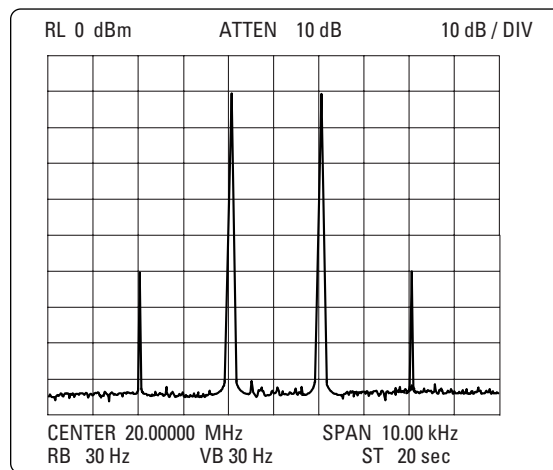

Figure 5. Example of intermodulation products caused by two sources intermodulating with each other.

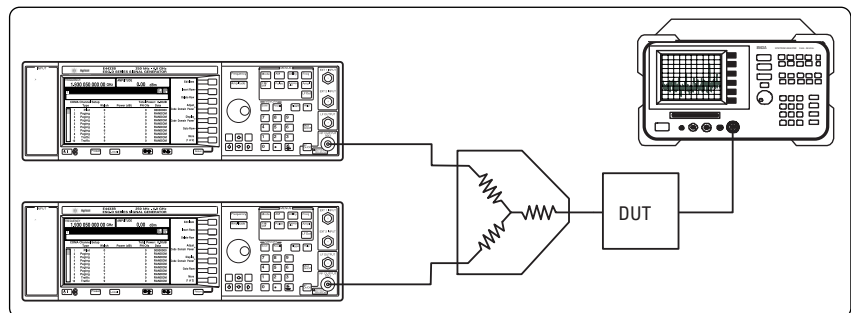

Figure 6. Three-resistor combiner used to isolate the outputs of the sources.

## HINT 6. Improve FM deviation accuracy

Do you want to set the deviation of your signal generator more accurately? The carrier-null method sets a signal generator's frequency deviation precisely.

Modulation Index:

$$\beta = \frac{\text{peak frequency deviation}}{\text{modulation frequency}}$$

(Formula A)

In frequency modulation, the spectral components (including the carrier component) change their amplitudes when  $\beta$  is varied. Bessel Function curves (Figure 7) show the relation between the carrier and sideband amplitudes of the modulated wave as a function of the modulation index,  $\beta$ . Note that the carrier component  $J_0$  and the various sidebands  $J_n$  go to zero amplitude at specific values of  $\beta$ .

You can adjust your signal generator to a precise frequency deviation with the aid of a spectrum analyzer and a frequency counter. Use one of the carrier zeros to select the appropriate modulating frequency.

For example, in Figure 8 the deviation is adjusted for the first carrier null. The modulating frequency is 10 kHz and  $\beta$  2.4 (first carrier null). Therefore using formula A, you obtain a carrier peak frequency deviation of exactly 24 kHz. Table 1 gives the modulation frequency for common values of deviation for the various orders of carrier nulls.

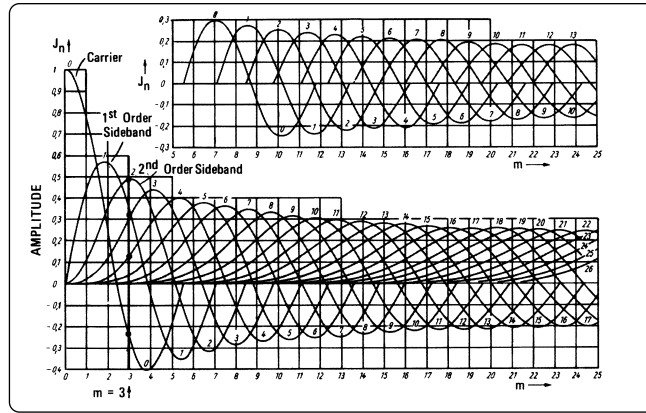

Figure 7. Bessel function curves show the relation between the carrier and sideband amplitudes of modulated wave as a function of  $\beta$ .

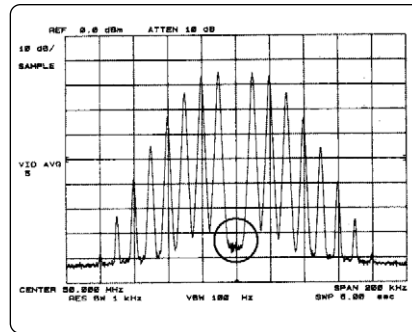

Figure 8. The spectrum of an FM signal at 50 MHz with deviation adjusted to first carrier null.

The procedure for setting up a known deviation is:

- 1). Select the column with the required deviation; for example, 250 kHz.
- 2). From the table select the carrier null that corresponds with the normal modulation bandwidth of use. For example, if 250 kHz was chosen to test an audio modulation circuit, it will be necessary to go to the fifth carrier null to get a modulating frequency within the audio passband of the generator (here, 16.74 kHz).

- 3). Use your frequency counter to set the modulating frequency to 16.74 kHz, and monitor the output spectrum of the generator on a spectrum analyzer. Increase the deviation of the carrier until the carrier amplitude has gone through four zeros and stop when the carrier is at its fifth minimum. With a modulating frequency of 16.74 kHz and the spectrum at its fifth zero, the setup provides a unique 250 kHz deviation.

Since we can accurately set the modulation frequency using the frequency counter, and the modulation index is also known accurately, the frequency deviation generated will be equally accurate.

Order of Carrier zero	Modulation Index	7.5 kHz	Commonly Used Values of FM Peak Deviation								
			10 kHz	15 kHz	25 kHz	30 kHz	50 kHz	100 kHz	150 kHz	250 kHz	300 kHz
1	2.40	3.12	4.16	6.25	10.42	12.50	20.83	41.67	62.501	04.17	125.00
2	5.52	1.36	1.18	2.72	4.53	5.43	9.06	18.12	27.17	45.29	54.35
3	8.65	.87	1.16	1.73	2.89	3.47	5.78	11.56	17.34	28.90	34.68
4	11.79	.66	.85	1.27	2.12	2.54	4.24	8.48	12.72	21.20	25.45
5	14.93	.50	.67	1.00	1.67	2.01	3.35	6.70	10.05	16.74	20.09
6	18.07	.42	.55	.83	1.88	1.66	2.77	5.53	8.30	13.84	16.60

Table 1. Modulation frequency for common deviation of the various orders of carrier nulls.



## HINT 7. Extend the amplitude range

An important specification of any signal generator is the output power range. If you need to go beyond this specified range, use an amplifier to increase or an attenuator to decrease the output power. When you extend the output amplitude range of the source by using one of these devices, there are some important factors to be aware of.

The amplifier gain uncertainty affects the output signal level directly. Be aware of the 1 dB compression point of the amplifier. If you need to drive the device too close to this compression point, use a low pass filter at the output to reduce the added harmonic distortion (Figure 9).

As in the case of the amplifier, there are uncertainties to consider when using an attenuator, such as attenuator flatness and accuracy. For the most accurate measurements, characterize the attenuator using a network analyzer and correct the source power to compensate for any attenuator error.

Interfering signals are an important source of error especially at very low amplitude levels. These signals are either from external radiation, for example a nearby radio station, or even leakage from the source itself. Leakage from the source affects the level input to the DUT and external noise affects the measurement data. To reduce the inaccuracies, place the DUT in a shielded environment such as a metal box (Figure 10), or a shielded room. A TEM (transverse electro-magnetic wave) cell may work as well. This will reduce the effect of the external radiation and any signal leakage from your attenuator or source provided they are outside of the cell.

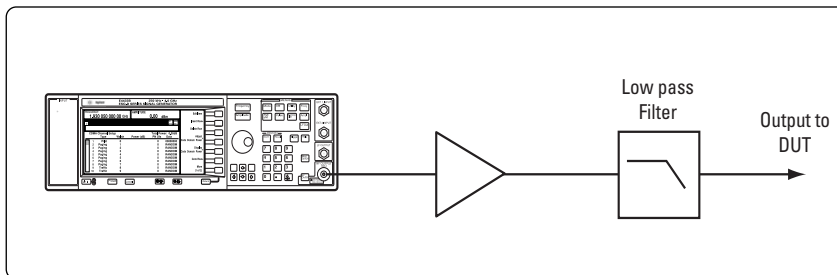

Figure 9. When increasing amplitude range, use a low pass filter to reduce added harmonic distortion.

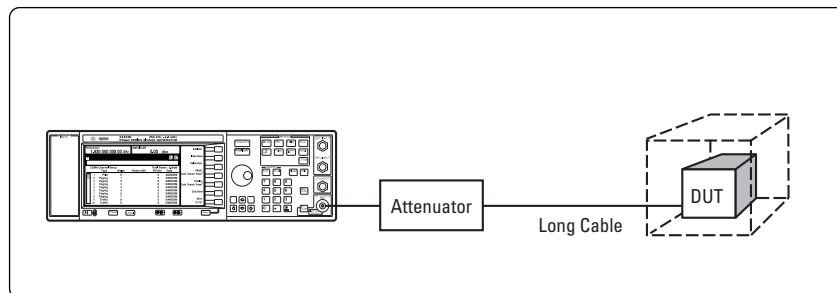

Figure 10. When decreasing amplitude range, place your DUT in a shielded environment.

**HINT 8.**  
**Select the optimum phase noise profile**

Random noise within the source will cause the power to be spread over a small range of frequencies. This spread is referred to as phase noise and is often mathematically modeled as random phase modulation. The units of phase noise are dBc/Hz: dB down from the carrier in a 1 Hz bandwidth. Phase noise is specified at a frequency offset from the source's output. For example, the phase noise of a source may be specified as -97 dBc/Hz @ 100 kHz offset from a signal frequency at 20 GHz.

Some recently designed signal generators have a choice of two phase noise modes; you can tailor performance to either in-channel or out-of-channel measurements.

If the phase-lock loop bandwidth of the synthesizer internal to your signal generator is widened, this will yield the minimum phase noise at lower offsets (such as < 10 kHz) for in-channel measurements, but at the expense of increased phase noise at higher offsets. Conversely, if a narrow phase lock-loop bandwidth is used, optimum phase noise will be achieved at higher offsets (such as > 10 kHz) for out-of-channel measurements. Now, the trade-off is increased phase noise at lower offsets.

Phase noise is generally displayed on a log-log axis. This enables both the close-in phase noise (offsets < 1 kHz) and the far-out phase noise (offsets > 10 kHz) to be easily examined on one plot. See Figure 11.

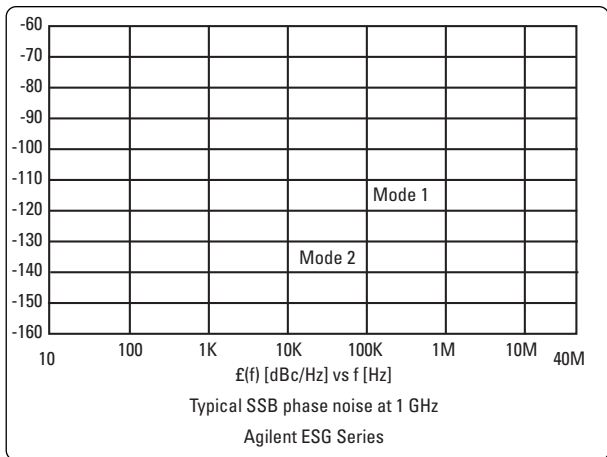

Figure 11.

## Guide to Agilent RF signal generators

### ESG Series

#### E4400B/E4420B/E4421B/E4422B

Excellent level accuracy,  $\pm 0.5$  ( $\pm 0.9 > 2$  GHz)

Choice of frequency coverage

Expandable architecture

Built-in function generator

Electronic attenuator

Step sweep at an economic price

- 250 kHz to 1/2/3/4 GHz
- +7,+10,+13 to -136 dBm
- AM, FM,  $\Phi$ M and pulse modulation



### Digital RF

#### E4430B/E4431B/E4432B/E4433B

Built-in modulation formats for CDMA, GSM, NADC, PDC, PHS, DECT and TETRA applications.

Excellent level accuracy and I/Q inputs.

- 250 kHz to 1/2/3/4 GHz
- +7,+10,+13 to -136 dBm
- AM, FM,  $\Phi$ M, Digital and pulse modulation
- Internal arbitrary waveform generator
- Flexible modulation generator



### High Performance RF

#### 8644B/8645A

Performance signal generator for RF design and manufacturing

- 252 kHz to 1.03 GHz (2.06 GHz with Option)
- +13,+16 to -137 dBm
- AM, FM and pulse modulation
- Residual FM at 1 GHz:  $<2/<1$
- Spurious (dBc):  $<-100$  ( $<-94$  with Option)



### Economy RF

#### 8648A/B/C/D

Low-cost synthesized signal generator series for manufacturing and service applications

- 9/100 kHz to 4 GHz
- +10, +13 to -136 dBm (up to +20 with Option)
- AM, FM,  $\Phi$ M and with Option pulse modulation



**By internet, phone, or fax, get assistance  
with all your test & measurement needs**

**Online assistance:**  
[www.agilent.com/find/assist](http://www.agilent.com/find/assist)

**Phone or Fax**

**United States:**

(tel) 1-800-452-4844

**Canada:**

(tel) 1-877- 894-4414  
(fax) (905) 282-6495

**China:**

(tel) 800-810-0189  
(fax) 1-0800-650-0121

**Europe:**

(tel) (31 20) 547-2323  
(fax) (31 20) 547-2390

**Japan:**

(tel) (81) 426-56-7832  
(fax) (81) 426-56-7840

**Korea:**

(tel) (82 2) 2004-5004  
(fax) (82 2) 2004-5115

**Latin America:**

(tel) (305) 269-7500  
(fax) (305) 269-7599

**Other Asia Pacific Countries:**

(tel) (65) 375-8100  
(fax) (65) 836-0252  
Email: [tm\\_asia@agilent.com](mailto:tm_asia@agilent.com)

Product specifications and descriptions in this  
document subject to change without notice.

© Agilent Technologies, Inc. 2001

Printed in U.S.A., November 14, 2001

5967-5661E