

Agilent Network Analysis Solutions Advanced Filter Tuning Using Time Domain Transforms

Application Note 1287-10

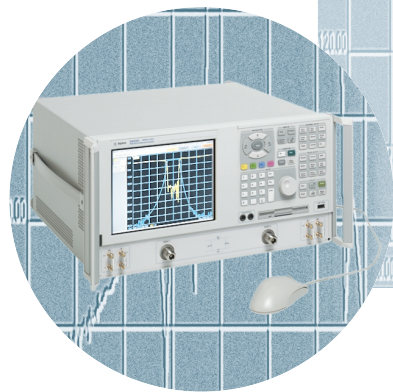

Introduction

The level of experience and expertise required to accurately tune coupled-resonator cavity filters, cross-coupled filters, and duplexers effectively precludes these devices from mass production at high speed. Ironically, these same filters are increasingly needed in large quantities, as a result of the spectral density resulting from the runaway success of wireless communications services. The time required to tune these filters accurately limits manufacturers from increasing their production volumes and reducing manufacturing cost. Fortunately, it is possible to dramatically reduce both the time required to tune these types of filters, as well as the experience and expertise required. The method removes filter tuning from the realm of art, and makes the process predictable and repeatable. Even relatively inexperienced filter tuners can tune multiple-pole filters with great success with a minimal amount of training.

The basic technique has been comprehensively covered in Agilent application note 1287-8, which also describes how coupled-resonator band-pass filters can be easily and deterministically tuned. To achieve the proper passband response, and to achieve good return loss and passband ripple, the center frequency of each resonator is precisely tuned, and each coupling between resonators precisely set. The method is based on the time-domain response of a filter's return loss, in which the time-domain response is obtained by a special type of discrete inverse Fourier transform of the frequency response. Readers are encouraged to review the material contained in application note 1287-8 for information about the basic technique and how it is applied to tuning coupled-resonator cavity filters.

This application note reviews these time domain tuning techniques, and extends the technique for use in tuning filters with cross-coupled resonators that produce transmission zeros near the filter passband, as well as duplexer filters that have a common (antenna) port, an upper passband (transmit) port, and a lower passband (receive) port.

Together with application note 1287-8, this application note provides a comprehensive compilation to filter tuning in the time domain, including theory, application, set-up, and tuning procedures.

The technique defined

A five-pole coupled resonator filter with four coupling structures will be used to illustrate the basic tuning technique. A schematic of the filter is shown in figure 1, with the distributed loss of the filter represented as shunt resistance. To apply the tuning method, the network analyzer's frequency sweep is centered at the desired center frequency of the bandpass filter. The frequency span is set to two to five times the expected filter bandwidth. The bandpass mode of time domain transform is applied to the return loss trace. Figure 2 shows the frequency response and the bandpass mode time response of the filter, a fifth-order Chebyshev with 0.25 dB of passband ripple.

Each plot shows two traces. The lighter (red) one is the filter return loss response with ideal values for all the components, and the darker (blue) trace shows the effect of mistuning one of the resonator elements (in this case, the second resonator). The upper plot is the frequency response and the lower plot is the time domain response. Notice the distinctive dips in the time response S11 of the filter (indicated by the triangles labeled 1-5). These are characteristic nulls that occur if the resonators are exactly tuned. If the center frequency of the measurement is changed even slightly, the nulls start to disappear, indicating that the filter is no longer tuned. The peaks between the nulls relate to the coupling factors of the filter. This type of response holds true for any all-pole filter, regardless of filter type.

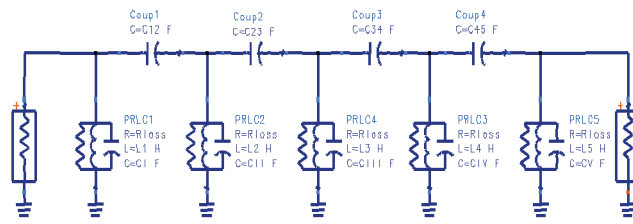

Figure 1.

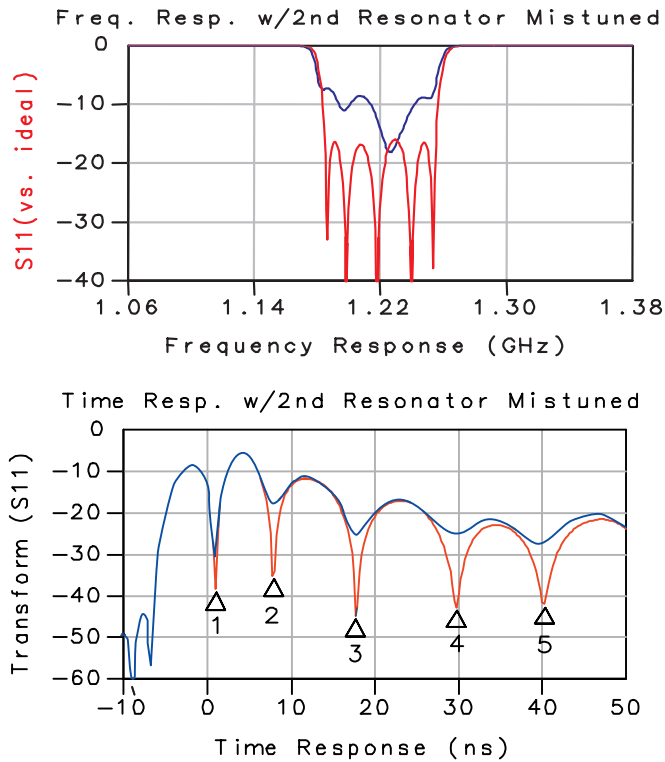

Figure 2.

The essence of the tuning technique is that the dips in the time domain response correspond exactly to each resonator in the filter. When the resonator is tuned properly, the null is deep. If the resonator is not tuned, the null starts to disappear. Though it may seem remarkable that this exact relationship exists, extensive testing with many different kinds of filters, as well as simulations and direct mathematical derivation, confirm this relationship. Figure 2 shows the time

domain response with only the second resonator mistuned from its ideal (derived) value. In this case the capacitor CII was tuned to a few percent above its ideal value. It is clear that the dip has nearly disappeared. The dip will only be maximized when the capacitor is returned to its ideal value. Note that mistuning one resonator can affect the response from the other "downstream" resonators.

Basic tuning method

The basic time domain tuning method for simple all-pole filters, is to measure the time domain response of S11 and S22 of the filter. The filter resonators are adjusted with the following steps:

1. Starting with the first and last resonators, tune to create a deep null in the time responses of the S11 and S22 measurements respectively (the nulls will be at approximately $t=0$).
2. The next resonator from the input and output are then tuned for deep nulls (which will appear approximately at $t=1/BW$ where BW is the filter bandwidth). Tuning the second resonator will slightly pull the first, since they are coupled.
3. The previous resonators (first and last, in this case) are readjusted to restore the null in the time domain trace to make it as deep as possible.
4. Continue in this manner, working in toward the center, until all the resonators have been adjusted for a deep null.

This first adjustment will exactly center the filter and provide optimum tuning for the given coupling factors. Many filters have adjustable coupling factors that must be tuned to generate the desired filter response, particularly bandwidth and return loss. The coupling adjustment can be accomplished with the following steps:

1. Create a filter template by measuring an existing tuned filter or from a filter simulation, and load it into the network analyzer's memory traces for S11 and S22.
2. After the initial resonator tuning described above, adjust the input and output coupling to match the amplitude of the first peak of the target S11 and S22 filter response. Readjust the first and last resonator to restore the first S11 and S22 nulls to make them as deep as possible.

3. Adjust the next coupling from the input and output to match the associated peak in the template response. Readjust the resonators adjacent to this coupling to restore the nulls to be as deep as possible.

4. Continue in this manner until all couplings have been adjusted to match the peaks of the filter template, and all resonators have their associated nulls as deep as possible.

Note that adjusting one coupling will affect all couplings that follow, so it is important to start with the couplings at the input and output and work toward the center.

Tuning filters with cross-coupled resonators

For many communication applications, it is necessary to make a filter skirt response steeper than normally obtained by all-pole type filters. Discrete transmission zeros (where the S_{21} goes to zero) can be obtained in the filter stopband by adding cross-coupling (coupling between resonators other than nearest neighbors). The number of resonators that the coupling “skips over” will determine the characteristics of the transmission zeros. Skipping over an odd number of resonators, as seen in figure 3, results in an asymmetric frequency response, with a zero on only one side of the passband. Skipping over two resonators results in transmission zeros on both sides of the passband. The time domain response of these filters differs from the all-pole filters, in that tuning the characteristic nulls to be as deep as possible does not result in the filter being properly tuned.

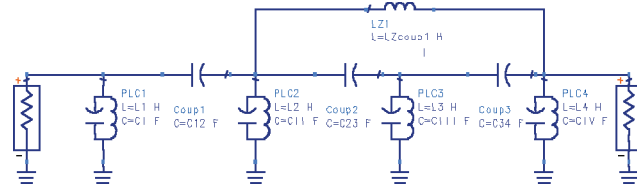

Figure 3.

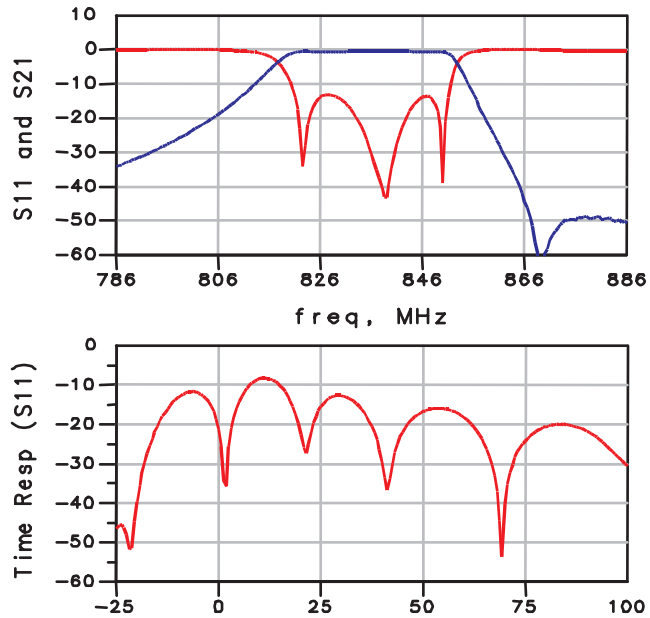

Figure 4.

Figure 4 shows the frequency and time response of the four-pole filter with asymmetric cross coupling from figure 3. The filter, in this case, had coupling adjustments for only the input, output, and cross-coupling. The coupling between resonators was fixed.

The filter was optimized for return loss in the passband and rejection in the upper stop band. Notice from the time response that the nulls are not deep for many of the resonators. The design methods for simple, all-pole filters help illustrate why this is so, and how to tune these filters.

All-pole filters

All-pole filters are designed by starting with a low-pass prototype filter, then applying a transform to shift it up in frequency from “DC-centered” to the desired center frequency. The essence of the design process is that the coupling values are derived only from the low-pass prototype component values. The resonator values are derived by making the resonant frequency of the node (which includes the input and output coupling) equal to the center frequency of the filter. For example, in the filter in figure 1, the resonant frequency of the second node is defined by the elements $L2$ in parallel with CII plus $C12$ and $C23$ (the coupling elements), and it exactly equals the filter center frequency. This is true for all the nodes, including the first and last, which have only one coupling added.

The time domain response of a filter node has a deep null whenever the frequency sweep of the network analyzer is exactly centered on the resonant frequency for that node. Further, the time domain response shows the response of the filter nodes separated in time. This separation is caused by the delay through each filter section, which Fano showed to be inversely proportional to the filter bandwidth. The time domain response will have sufficient resolution if the frequency sweep is at least twice as wide as the filter bandwidth.

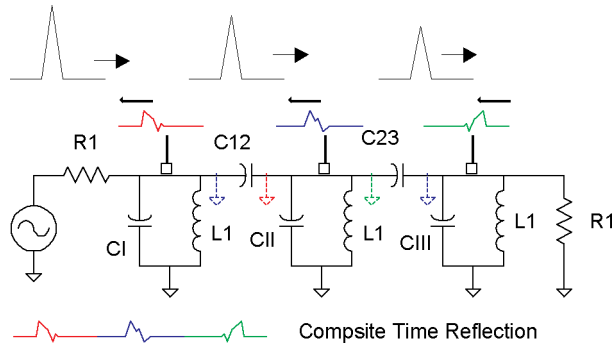

Figure 5. The time domain response separates the response from each node.

To illustrate this point, consider the response of a filter to an impulse, as shown in figure 5. As the impulse proceeds through each node of the filter, part is reflected and most is transmitted. If the filter is uncharged before the pulse arrives, the reflection from the first node will look as though the coupling capacitance, $C12$, is grounded on the far side. That is, the time domain reflection will be the same as a circuit that is tuned to the “node frequency” consisting of $C12 + C1$ in parallel with $L1$. Since the pulse goes to zero after

time zero, the reflection from node 2 will look as though both $C12$ and $C23$ are grounded. The delay between these pulses will be due to the coupling, so less coupling (which results in a narrower filter) will have more delay. This is the same relationship used to design the all-pole filter. It then becomes clear why tuning for deep nulls with the network analyzer tuned to the filter center frequency succeeds: The response from each individual node is centered on the same frequency.

Effects of cross coupling

With cross-coupling added to the filter, the time domain response no longer has the simple relationship to filter tuning. Further, especially in filters with asymmetric transmission zeros, tuning of the filter is not optimum when each node frequency is tuned to the filter center frequency. Recall that the node frequency is defined to be the resonant frequency of the node with all connected couplings, including cross coupling, grounded. The resonators are often “pulled” to compensate for the effect on the pass-band of the transmission zeros in the stopband, thus achieving the desired passband return loss specification. This results in an asymmetric shape to the return loss, as demonstrated in figure 4. Tuning for deep nulls results in a filter that does not meet the return loss specifications. However, the discussion about figure 5 points to a method that will allow tuning filters with cross coupling in the time domain.

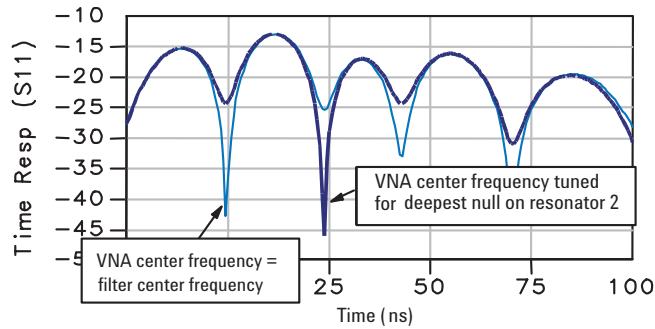

Figure 6. Change in time response when the VNA center frequency is tuned.

The argument still holds for the time response of any particular node of a filter having a deep null when the node frequency is exactly centered on the network analyzer frequency. The difficulty with these complex filters is that the node frequencies are no longer easy to determine. But the network analyzer itself can be used, on a properly tuned or “golden” filter, or on a simulated filter, to discover the individual node frequencies. This is done by setting up the vector network analyzer (VNA) in dual-channel mode, with one channel on frequency domain and one on time domain. The center frequency of the VNA is adjusted while looking at the null associated with a particular resonator. When the null is maximized, that frequency is recorded as the node frequency for that resonator.

Table 1. Node frequency for each resonator

Resonator no.	Node frequency
1	836.25 MHz
2	833.85 MHz
3	834.55 MHz
4	836.45 MHz

Figure 6 illustrates the time response of the filter tuned at the filter center frequency, and then tuned to a frequency that maximizes the null associated with resonator 2 (one of the resonators with cross coupling).

This process is repeated for each of the filter’s resonators, adjusting the VNA center frequency until each null is maximized. For best sensitivity, the frequency span is reduced to just two times the bandwidth. Table 1 gives the node frequencies determined for each resonator for the filter from figure 4. Armed with this information, and using the measurement from figure 4 as the tuning template, a filter tuning process for complex filters can be defined.

Tuning of complex filters

The filter from figure 4, with all four resonators, the input and output coupling, and the cross coupling detuned, is used to demonstrate this process.

1. Assuming that the input and output coupling is sufficient to produce an approximate filter shape, start by tuning the filter as though it were an all-pole filter. Figure 7 shows the frequency response before any tuning, and after the resonators (but not coupling) have been adjusted for maximum nulls.

2. Adjust the coupling to align the time domain response peaks with those of the target filter, remembering to readjust the resonators to get deep nulls. Figure 8 shows the result of coupling adjustment.
3. Adjust the cross coupling to set the zero frequency to match the S21 frequency response target, as shown in figure 9.

4. Finally, to get the resonators tuned to their correct final values, set the VNA center frequency to that listed in table 1 for each resonator, and tune that resonator for maximum null. After a first pass, go back again and retune each resonator to account for the pulling effect of tuning the other resonators. Figure 10 shows the final result of tuning this filter. It is clear that the final response is nearly identical. Remember that the return loss tuning was done entirely in the time domain.

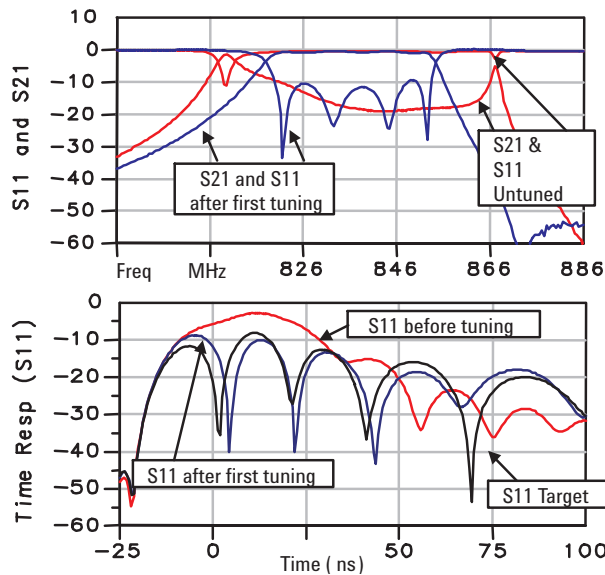

Figure 7.

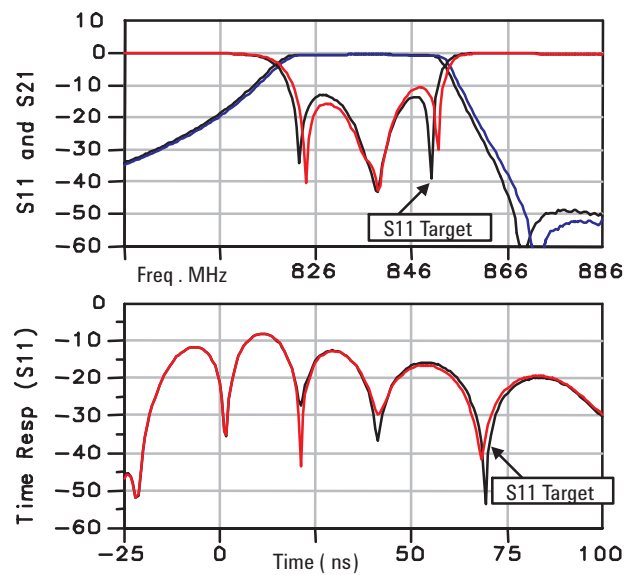

Figure 8.

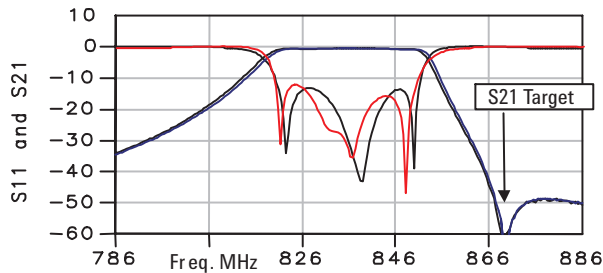

Figure 9.

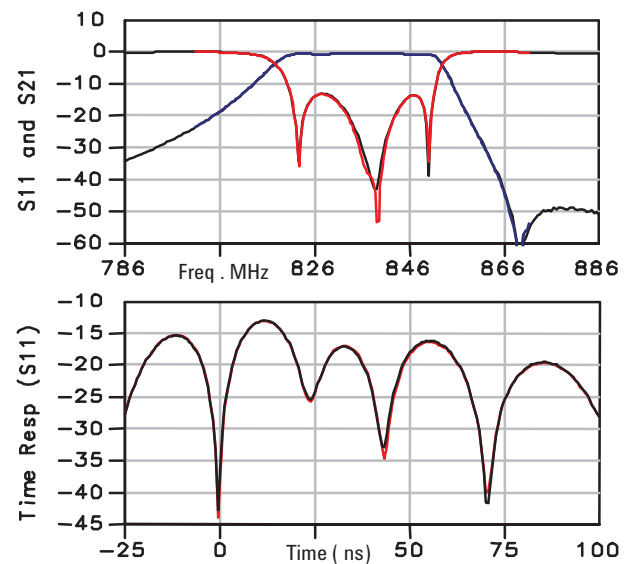

Figure 10.

Duplex filter tuning

Duplex filters (sometimes called duplexers), as seen from the antenna port, have two paths that contribute to the return loss response, each with its own delays and responses. The task for the filter tuner, and the focus of this section, is to separate these responses so that each side of the filter can be deterministically tuned.

Duplex filters are used primarily to separate the transmission channel (Tx) from the receive channel (Rx) in a wireless communications base station. Because the Tx and Rx are nearly adjacent, the filters tend to be very asymmetric to create sharp cutoffs for each band. Figure 11 shows the schematic of such a duplexer. Note that a single cross-coupling is used in each side, but that the cross-coupling is capacitive in one side and inductive in the other. This gives a lower transmission zero for the Rx band (Rx is upper in this case) and an upper transmission zero in the Tx band as shown in figure 12.

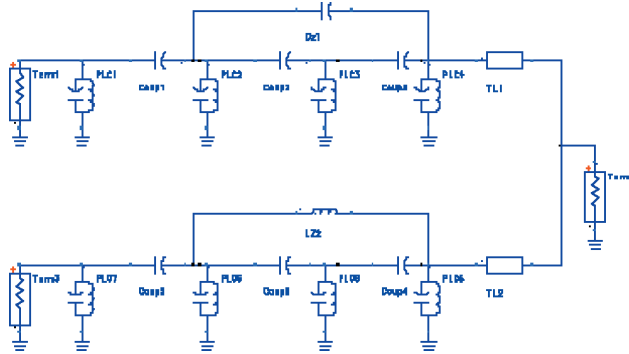

Figure 11.

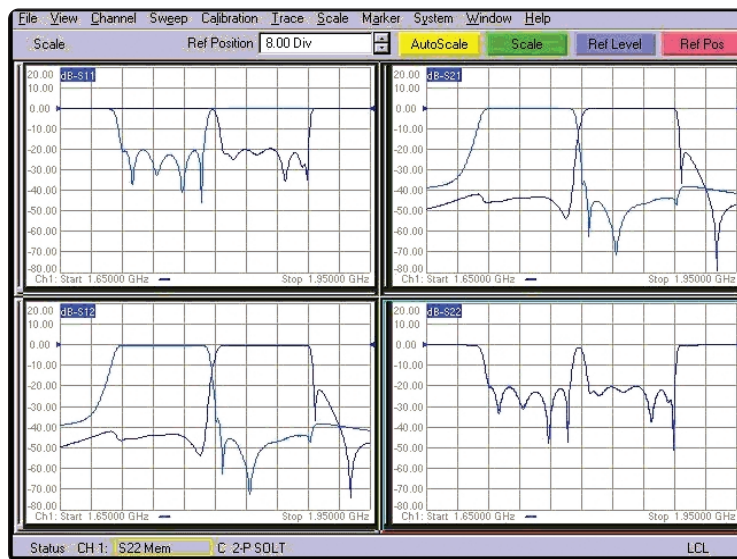

Figure 12.

Duplexers that have more than a bandwidth of separation between the Tx and Rx bands are easily tuned with the method noted above for tuning filters with cross-coupling. That is because the network analyzer can be centered on the Tx band, with the span at greater than two bandwidths, and still not have the Rx band interfere with the input or output reflection response. However, most duplexers have substantially less than one bandwidth between the edges of the Tx and Rx bands (a typical filter might have an 80 MHz bandwidth with 20 MHz of separation). These types of duplexers make time-domain tuning difficult, because

resonator responses at the common port can come from either the Tx side or the Rx side.

In figure 11, the duplexer uses quarter-wave transformers to isolate each side of the duplexer (the input impedance of the Tx side is a short circuit at the Rx frequency). Other topologies couple the common port to a broader-band common resonator, which is in turn coupled to the first resonator on both the Tx and Rx sides. With this configuration, the common resonator clearly cannot be centered on either the Tx or Rx passbands, instead it is centered somewhere in between.

Time domain response of duplexers

The time domain response of duplexers is complicated by the fact that at the common port, reflections from both the Tx side and Rx side will cause some nulls in the time domain. Figure 13 shows the time domain and frequency response of a real duplexer. To view the time-domain response in a way that makes sense, it is necessary to set the network analyzer center frequency to the frequency between the Rx and Tx passbands. The span of the analyzer must be set to at least two times the overall bandwidth of the Tx and Rx bands.

Setting up the tuning process
 Just as with the complex filter of figure 4, the tuning process for a duplexer requires a properly tuned prototype filter to allow the node frequencies and target couplings to be determined. However, the nodes will be more difficult to associate with individual resonators, especially from the common port.

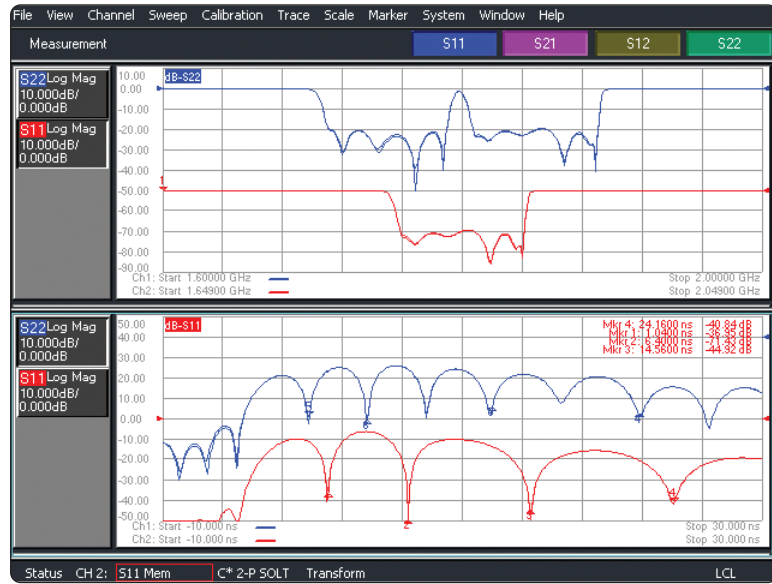

Figure 13. Top half of display: Upper trace = antenna common
 Lower trace = Rx
Lower half of display: Upper trace = antenna common
 Lower trace = Rx

Identifying the resonator

The upper half of figure 13 shows that there are more nulls in the time domain response of the reflection from the common port than there are from the Tx port. The first null is associated with the common resonator (figure 14). The second null association is found by changing the tuning slightly on the last Tx resonator, and in the same manner the last Rx resonator can be associated with the third null from the common port (figure 15). Depending upon the filter, it may also be possible to identify other resonators in the Tx or Rx filter, but soon the nulls become confusing, with the tuning of one resonator affecting two nulls.



Figure 14. Tuning the common ANT resonator shows a response change primarily in the first null. In this way the first node resonator is determined and the first node frequency can be found by changing the VNA frequency to find the deepest null

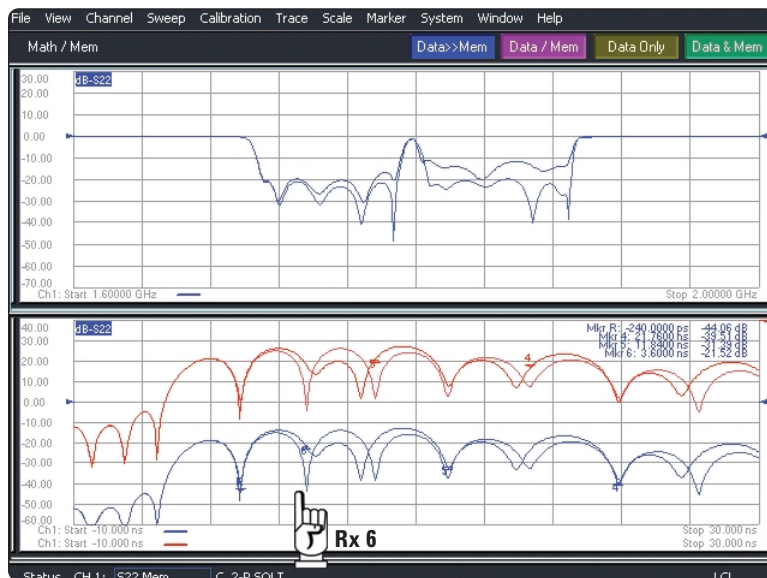

Figure 15. Tuning the Rx 6 resonator shows the primary effect at the second null. By looking for the frequency of the VNA, which makes the null deepest, we know this node frequency. Note: the next null also shows some effect from tuning

Finding node frequencies

Once the association of nulls with resonators has been done from the common port for the last Tx and Rx resonators, the individual node frequency for each resonator is found by tuning the analyzer's center frequency until the associated null is deepest. This frequency is also recorded for each null while measuring reflection from the Tx and Rx ports, and for the first several nulls from the common port. These frequencies (in MHz) are shown in table 2.

Separating Tx and Rx Responses

These node frequencies will be used for the final tuning of the duplexer, but experimental research shows that it is not practical to try to tune the duplexer directly to these frequencies. This is because there is so much interaction from the Rx side on the Tx response, especially at the common port, that the resonators cannot be sufficiently isolated unless they are already very close to their correct values. The solution for initial tuning is to mistune one side (say the Tx side) and then recharacterize the filter for the Rx side node frequencies. Figure 16 shows the response of the duplexer with Tx5 (the one closest to the common port resonator) mistuned.

In figure 16, the VNA center frequency is changed such that the null associated with the Rx 6 resonator measured at the common port is deep (time domain, upper trace). This frequency is recorded in table 3 as Rx 6 frequency. But with the same filter measured at the Rx port, with an analyzer center frequency of 1850 MHz (time domain, lower trace), each Rx node is nearly a null.

Table 2. Node frequency for tuned duplexer

Common port		Tx port		Rx port	
Node	Freq.	Node	Freq.	Node	Freq.
Com	1800	TX1	1747	RX1	1848
RX6	1800	TX2	1749	RX2	1848
TX5	1796	TX3	1750	RX3	1851
RX5	1805	TX4	1760	RX4	1841
TX4	1788				
RX4	1810				

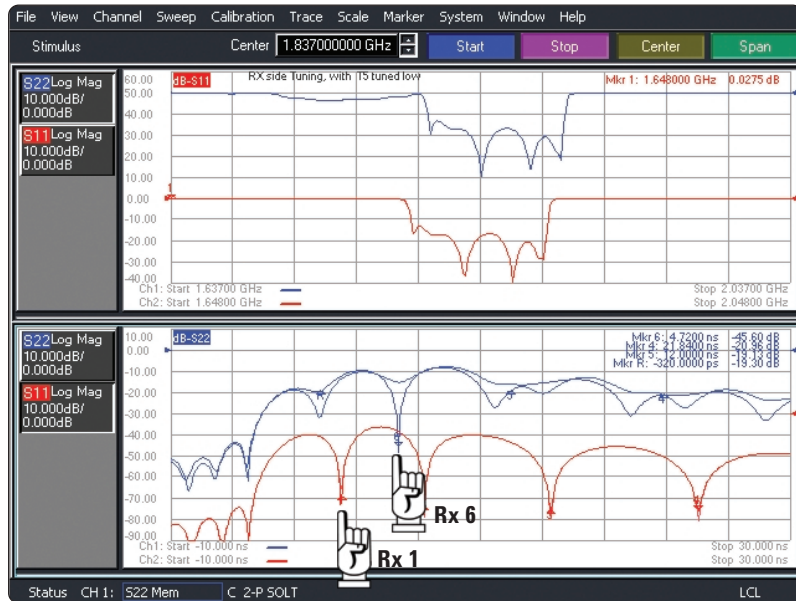

Figure 16. The upper trace shows the Rx path frequency response with a VNA center frequency selected to obtain the deepest null for the respective resonators. These frequencies are recorded for the Rx filter tuned and the Tx first resonator tuned low.

Table 3. Node frequency for duplexer with sides isolated

Common Port		Tx Port *		Rx Port **	
Node	Freq.	Node	Freq.	Node	Freq.
Com	1803** 1793*	TX1	1746	RX1	1848
RX6**	1829	TX2	1749	RX2	1848
TX5*	1762	TX3	1749	RX3	1850
RX5**	1848	TX4	1787	RX4	1850
TX4*	1738				
RX4**	1860				

*Rx untuned; **Tx untuned

After the Rx frequencies are determined, the Rx 6 resonator is set high, and the Tx resonator frequencies are determined in a similar way. The precise node frequency for each node was recorded in table 3.

Note that from the Tx and Rx ports, the node frequencies are nearly unchanged, indicating that these are very nearly isolated from their respective other sides even in a tuned duplexer.

Tuning a filter

A duplexer tuning process proceeds as follows:

1. Start with resonator RX6 tuned high in frequency. Tune the Tx side of the filter, and common port according to the starred (*) frequencies in table 3. Tune coupling and cross-coupling as described in application note 1287-8.
2. Tune resonator TX5 as low as possible. Tune the Rx side of the filter using the double starred (**) frequencies in table 3. Figure 17 shows tuning starting with Rx1 and common. The result of tuning all Rx resonators is shown in figure 18. The VNA is set to the common resonator frequency (about 1800 MHz) so the Rx nulls don't appear deep. Here, Tx 5 resonator is not yet tuned.
3. Final tune TX5 and TX6 to the frequency in table 2. Final tune all resonators to table 2 values. Results shown in figure 19.

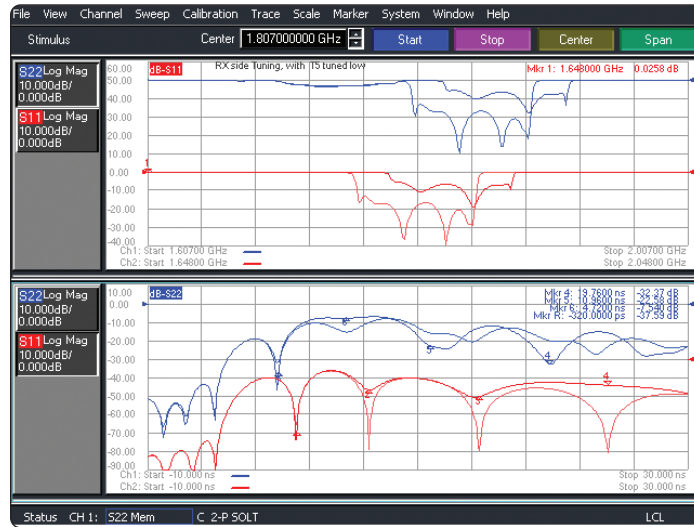

Figure 17. The Rx side of the filter is being tuned here. The upper plot shows the S11 and S22 of the filter; each set to a different center frequency appropriate for the first and last resonator. The lowest plot shows the null from each resonator.

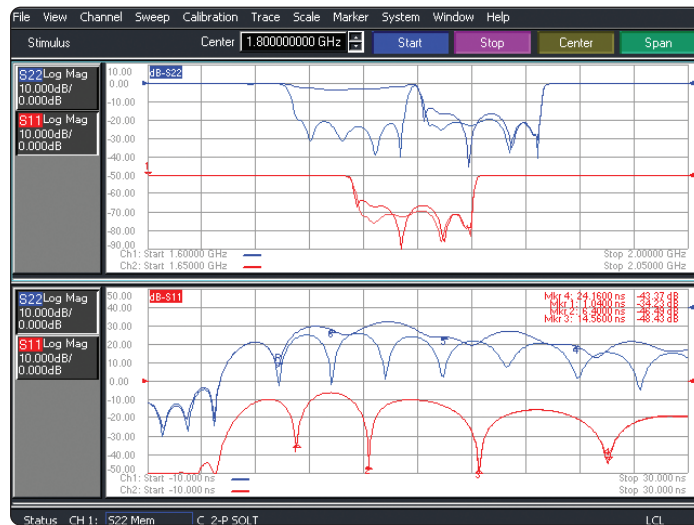

Figure 18.

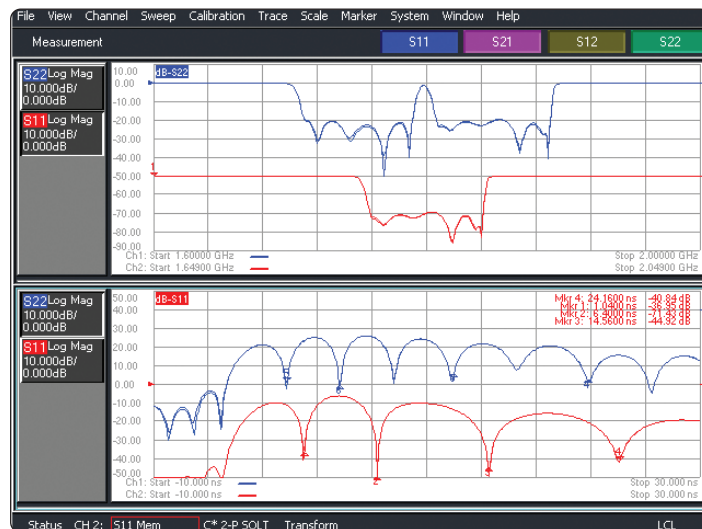

Figure 19.

More complex filter tuning

Dealing with multiple or strong cross couplings

In the example filter shown in figure 3, the coupling value for the cross coupling was much less than the main coupling. For such cases, the cross coupling does not have a strong effect on the time domain response.

However, some filters have very strong cross coupling (coupling of the same order as the main coupling), or multiple cross couplings. In these cases, it may be necessary to take a different approach to tuning the filters.

One approach that has been effective is to remove the cross couplings (either by tuning them to a very low value, or shorting out cross couplings if they are not adjustable). This will result in a filter that does not have the desired shape, but does have the correct settings for the resonators and main coupling.

This is similar to the method used to isolate the Tx side of the duplexer from the Rx side. The resulting filter has only one path for coupling, and can be characterized as an all pole filter. A “golden” trace of this filter can be captured without the cross coupling.

When tuning an untuned filter, it can be set to have the same response as the “golden” filter, with the cross coupling removed. All that remains is to set the cross coupling back to verify the final filter response.

Another option for filters with adjustable cross couplings is to set the cross coupling first, before tuning the rest of the filter. This method may be effective for filters where the cross coupling has a strong effect on the

pass band response. To do this, one may short out the resonators beyond the cross coupling, essentially making a new filter with the cross coupling being the main path through the filter. A “golden” trace may be taken with a filter thus modified, and the value of the cross coupling in the time domain may be recorded. When tuning an untuned filter, the process is reversed. The resonators beyond the cross coupling are shorted and the cross coupling is set in the time domain. The shorting of the resonators is removed, and the filter is tuned as described above. This may be effective in dealing with cross coupling that is used for linearizing group delay in filters.

Conclusions

In this application note, we have shown ways to extend the time domain tuning techniques to more complex filters. These filters may contain complex transmission responses, with cross couplings. These filters may also contain multiple paths, such as in duplexers, or even multiplexers. While good progress has been made on extending these techniques, there remain many opportunities for enhancements to these methods, and many filter types that require further investigation. Agilent Technologies is continuing research into the area of filter tuning, and will continue to provide state-of-the-art tuning techniques and applications to support innovation in the area of coupled resonator filter design.

Other resources

Tuning coupled resonator cavity filters

1. Joel Dunsmore, "Simplify Filter Tuning Using Time Domain Transforms", *Microwaves & RF*, March 1999.
2. Joel Dunsmore, "Tuning Band Pass Filters in the Time Domain, *Digest of 1999 IEEE MTTT Int. Microwave Sym.*, pp. 1351-1354.
3. "Simplified Filter Tuning Using Time Domain," Application note 1287-8, literature number 5968-5328E

Tuning cross-coupled resonator filters

4. Joel Dunsmore, "Advanced Filter Tuning in the Time Domain," *Conference Proceedings of the 29th European Microwave Conference*, Vol. 2, pp. 72-75.

Tuning duplexer filters

5. Joel Dunsmore, "Duplex Filter Tuning Using Time Domain Transformers," *Conference Proceedings of the 30th European Microwave Conference*, Vol. 2, pp. 158-161.

Filter design

6. Zverev, "Handbook of Filter Synthesis," John Wiley and Sons, 1967.
7. Williams and Taylor, "Electronic Filter Design Handbook, 2nd Edition," McGraw Hill Publishers, Chapter 5, 1988.

Agilent Technologies' Test and Measurement Support, Services, and Assistance

Agilent Technologies aims to maximize the value you receive, while minimizing your risk and problems. We strive to ensure that you get the test and measurement capabilities you paid for and obtain the support you need. Our extensive support resources and services can help you choose the right Agilent products for your applications and apply them successfully. Every instrument and system we sell has a global warranty. Support is available for at least five years beyond the production life of the product. Two concepts underlie Agilent's overall support policy: "Our Promise" and "Your Advantage."

Our Promise

Our Promise means your Agilent test and measurement equipment will meet its advertised performance and functionality. When you are choosing new equipment, we will help you with product information, including realistic performance specifications and practical recommendations from experienced test engineers. When you use Agilent equipment, we can verify that it works properly, help with product operation, and provide basic measurement assistance for the use of specified capabilities, at no extra cost upon request. Many self-help tools are available.

Your Advantage

Your Advantage means that Agilent offers a wide range of additional expert test and measurement services, which you can purchase according to your unique technical and business needs. Solve problems efficiently and gain a competitive edge by contracting with us for calibration, extra-cost upgrades, out-of-warranty repairs, and on-site education and training, as well as design, system integration, project management, and other professional engineering services. Experienced Agilent engineers and technicians worldwide can help you maximize your productivity, optimize the return on investment of your Agilent instruments and systems, and obtain dependable measurement accuracy for the life of those products.

By internet, phone, or fax, get assistance with all your test & measurement needs

Online assistance:

www.agilent.com/find/assist

Phone or Fax

United States:

(tel) 1 800 452 4844

Canada:

(tel) 1 877 894 4414

(fax) (905) 282-6495

Europe:

(tel) (31 20) 547 2323

(fax) (31 20) 547 2390

Japan:

(tel) (81) 426 56 7832

(fax) (81) 426 56 7840

Latin America:

(tel) (305) 269 7500

(fax) (305) 269 7599

Australia:

(tel) 1 800 629 485

(fax) (61 3) 9210 5947

New Zealand:

(tel) 0 800 738 378

(fax) 64 4 495 8950

Asia Pacific:

(tel) (852) 3197 7777

(fax) (852) 2506 9284

Product specifications and descriptions in this document subject to change without notice.

Copyright © 2001

Agilent Technologies

Printed in USA, March 13, 2001

5980-2785EN



Agilent Technologies